

Hypertherm[®]

XPR™ plasma

Unmatched performance. Unbeatable operating cost.





Contents

4	XPR™ overview
6	Industry leading X-Definition® cut quality
10	Optimized productivity and reduced operating costs
12	Engineered system optimization
14	Ease of use
17	Reliability
19	50 years of Shaping Possibility

XPR overview

Unmatched performance. Unbeatable operating cost.

The new XPR™ plasma represents the most significant advance in mechanized plasma cutting technology, ever. These next generation systems redefine what plasma can do by expanding its capabilities and opportunities in ways never before possible. With unmatched X-Definition® cut quality on mild steel, stainless steel and aluminum, XPR increases cut speed, dramatically improves productivity and slashes operating costs. New ease-of-use features and engineered system optimization make XPR easier to run with minimal operator intervention, while also ensuring optimal performance and unmatched reliability.

Industry leading cut quality – X-Definition

The XPR advances HyDefinition® cut quality by blending new technology with refined processes for next generation, X-Definition cutting on mild steel, stainless steel and aluminum.

- Consistent ISO range 2 results on thin mild steel
- Extended ISO range 3 cut quality results compared with earlier plasma technology
- Superior stainless steel cut quality across all thickness ranges
- Superior results on aluminum using Vented Water Injection™ (VWI)

Optimized productivity and reduced operating costs

- Dramatic improvement in consumable life on mild steel applications
- Thicker piercing capability than competitive plasma systems
- Significantly lower operating costs than previous generation technology
- High quality argon marking using the same cutting consumables

Engineered system optimization

- Ramp down error protection significantly increases realized consumable life
- Reduces the impact of catastrophic electrode blowouts which can damage the torch at high current levels



Consistent cuts on mild steel, stainless steel and aluminum.

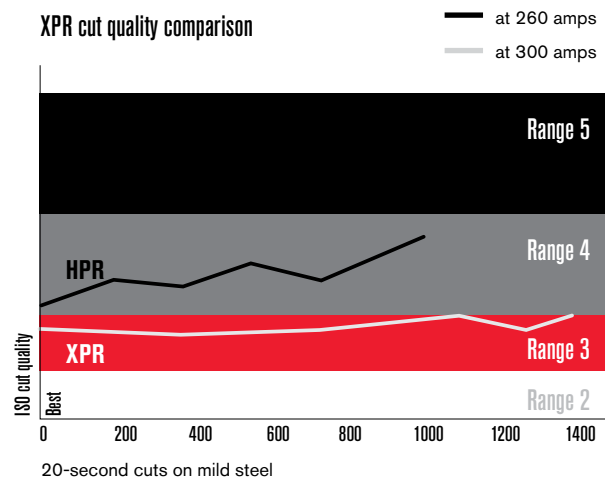

Ease of use

- Intuitive operation and automatic monitoring redefine ease of use
- Full control of all functions and settings via the CNC
- Automatic system monitoring and specific troubleshooting codes for improved maintenance and service prompts

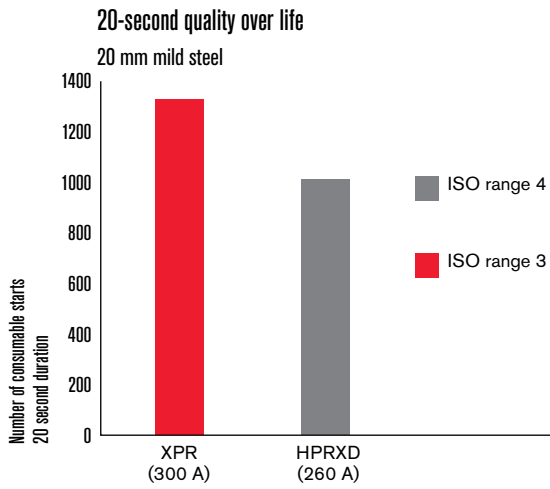

- EasyConnect™ torch lead and one hand torch-to-receptacle connection for fast and easy change-outs
- QuickLock™ electrode for easy consumable replacement
- WiFi in power supply can connect to mobile devices and LAN for multiple system monitoring and service



Industry leading X-Definition cut quality

Torch and consumable technology

X-Definition® improves cut quality and consistency on mild steel, expands the application of Hypertherm's pioneering HyDefinition® process to a broad range of non-ferrous applications and greatly enhances it with a number of critical new cutting technologies.

Expanded HyDefinition technology

Hypertherm's pioneering HyDefinition® technology, featuring a unique two-piece vented nozzle design, aligns and focuses the plasma arc, increasing arc stability and energy density for more consistent, precise cut quality. Previously used primarily on mild steel applications, this foundational technology is now applied to the full range of non-ferrous cutting processes for cleaner, sharper, more consistent edge quality on stainless steel and aluminum.

Vented Water Injection (VWI)

This patent pending process features a vented N₂ plasma and an H₂O shield. Edges are square, angularity is reduced and surface finish is excellent on non ferrous materials, especially aluminum.



Cool nozzle

Patent pending feature on the 300-amp oxygen process provides liquid cooling directly to the nozzle bore. This cooling is a significant factor in increasing cut quality over the life of the consumables by over 40%.

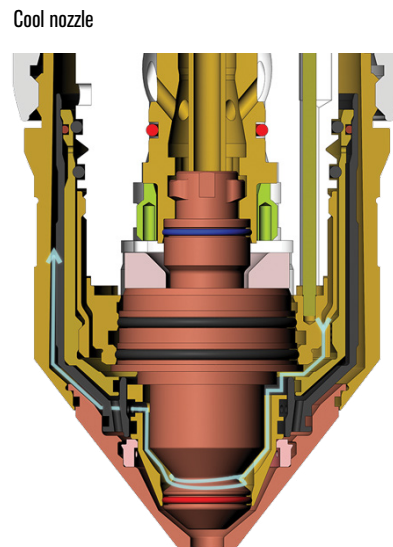

Vent-to-shield technology

This new technology mixes hydrogen reclaimed from the vented plasma gas with the shield gas to reduce angularity and deliver more consistent edge color on stainless steel up to 12 mm.

Plasma dampening

Patent pending plasma dampening delivers increased arc density and cut speeds on thin stainless while maintaining arc stability and smoother cut edges.

PowerPierce

Patented PowerPierce® liquid cooled shield technology repels molten metal during piercing allowing production piercing of 45 mm on mild steel all the way up to 50 mm on the XPR300 and up to 40 mm on the XPR170 when using Hypertherm's exclusive argon-assist process.



Advanced arc stability

Superior arc steadiness from a modified shield gas impingement improves arc stability when coming out of a pierce hole or out of an acute angle delivering reduced lead-in lengths and improved cut quality.

Improved torch geometry

Superior bevel capability and performance thanks to an enhanced tapered torch design that features a 76° included angle and bevel rotation of up to 52°.

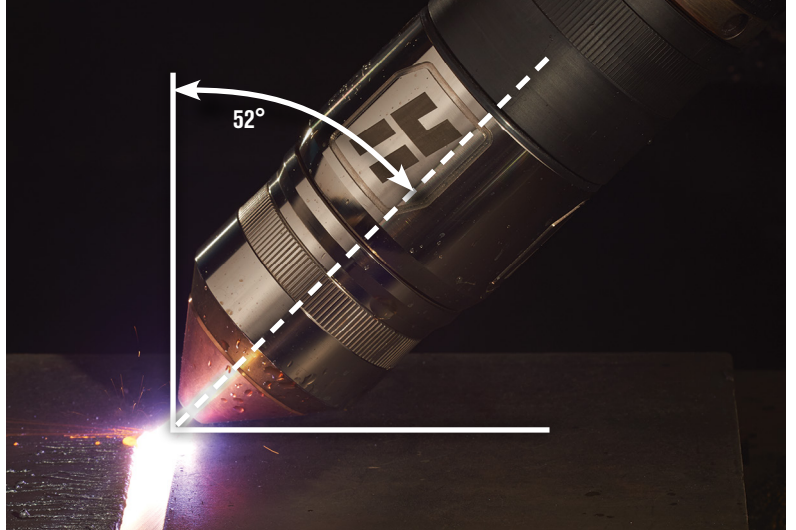

True Hole technology

XPR™ True Hole® technology incorporates new arc segmentation protocols to automatically produce bolt hole quality on mild steel with diameter to thickness ratios of 1:1 up to 2:1.



Process control and delivery.

State-of-the-art process control through a completely new concept in gas and fluid delivery. Three console options – Core™, Vented Water Injection™ (VWI) and OptiMix™ – offer unmatched mild steel cut quality with each console delivering successively enhanced cutting capabilities on stainless steel and aluminum. All consoles can be fully controlled through the CNC for high productivity and ease of use.



Gas-connect console gases/fluids			
	Core	Vented Water Injection (VWI)	OptiMix
O ₂ /N ₂ /Air	•	•	•
F5/Ar/H ₂ O		•	•
H ₂ -N ₂ -Ar mixing			•



Core™ console

Unmatched mild steel cutting performance and superior angularity and edge finish on stainless steel up to 12 mm. This is delivered through a new N₂ HDi® process that prevents the mixing of air into the plasma gas, creating an improved, brighter edge finish.



Vented Water Injection™ (VWI) console

All Core console capabilities plus argon marking and a more than 10% increase in piercing thickness with argon-assist. Significantly enhanced stainless steel and aluminum capabilities are delivered with the addition of F₅ HDi processes and patent pending Vented Water Injection (VWI).



OptiMix™ console

All the capabilities of the Core and VWI consoles plus discrete 3-gas mixing – Ar, H₂, and N₂ – for the world's most flexible, premium stainless steel and aluminum cutting capability.



Optimized productivity and reduced operating costs

Building on Hypertherm's industry-leading productivity technologies, XPR™ delivers faster cut speeds, higher quality cuts that reduce or eliminate secondary operations and increased consumable life with quicker set up time. These combine to further slash plasma system operating costs.

Technology benefits

- A valve in the torch receptacle delivers more rapid and precise control over gas flows for significantly longer oxygen process life and a greatly accelerated ramp down process. This elimination of ramp down errors in most applications enables a consumable life span nearly 3 times longer than other systems.
- New Cool nozzle™ flow technology contributes significant consumable life increases with greater ISO range 3 results than ever before.
- Increased power and argon-assist piercing delivers much thicker piercing capacity on mild steel for further productivity benefits.
- High quality argon marking using the same cutting consumables allows for a rapid and efficient changeover.

		XPR170	XPR300
Maximum output power		35,7 kW	66,5 kW
100% duty arc voltage		210 V	222 V
Cut chart thickness		mm	mm
Pierce capacity	Mild steel (argon-assist)	40	50
	Mild steel (standard O ₂)	35	45
	Stainless steel	22	38
	Aluminum	25	38
Severance capacity	Mild steel	60	80
	Stainless steel	38	75
	Aluminum	38	50
Cut angle	ISO 9013 range	2-4	2-4

Number of 20-second starts

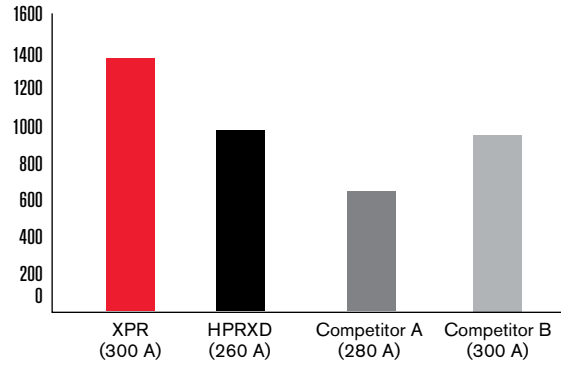

Number of 20-second starts

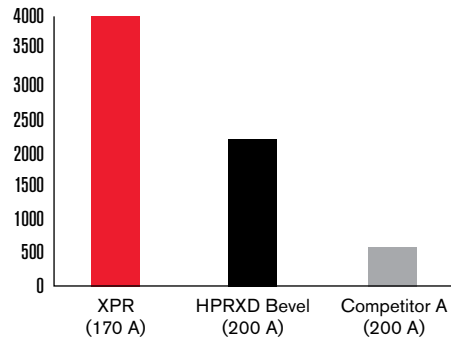

Argon marking





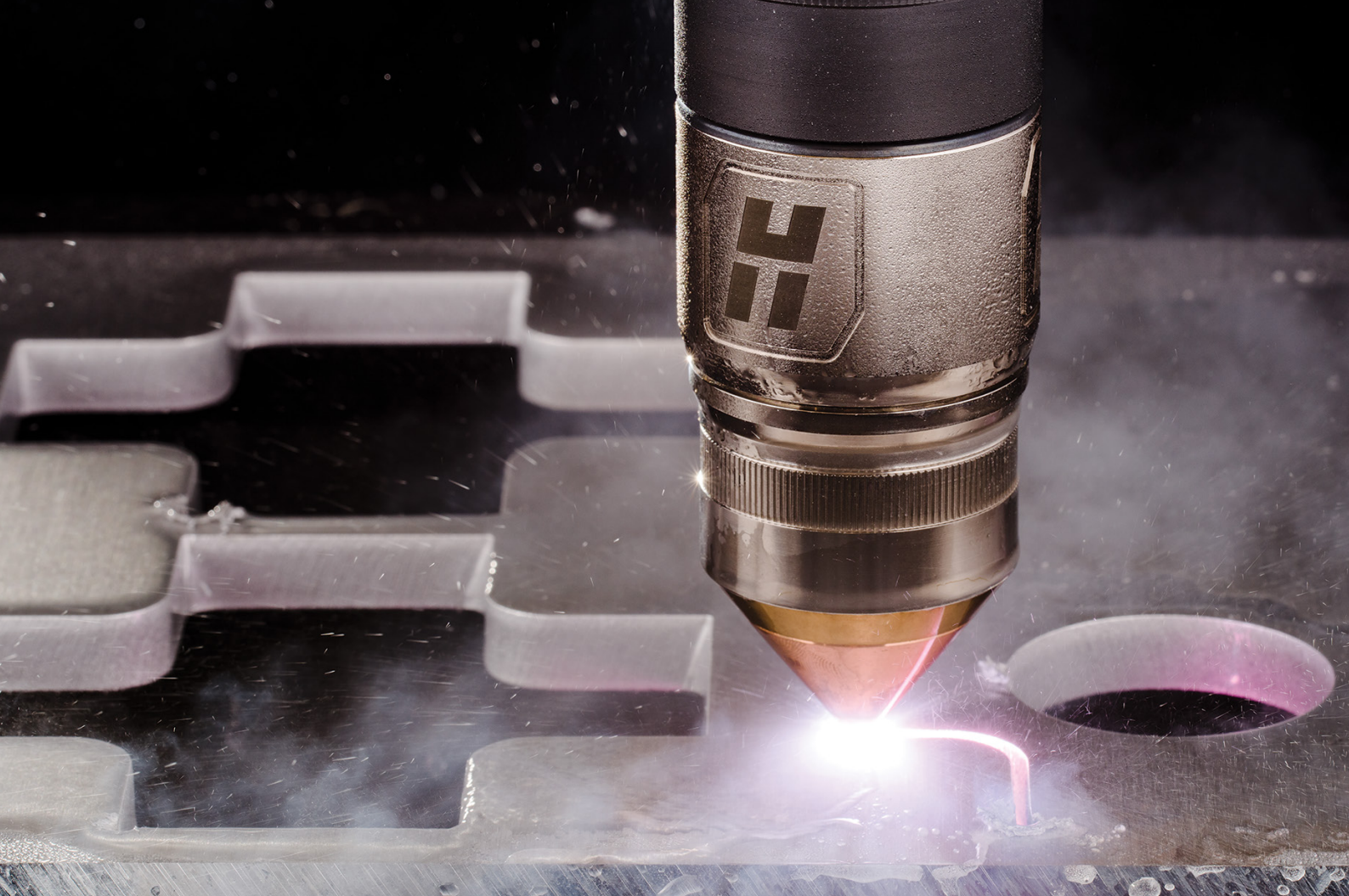

Engineered system optimization

XPR™ is engineered to deliver the highest quality cuts and optimal system performance automatically. Advanced power supply technology delivers highly responsive, rapid system feedback, and automatically intervenes to eliminate events that negatively impact system efficiency and consumable life.

Improved operating and troubleshooting information

Sensors in the power supply deliver refined diagnostic codes and significantly enhanced system monitoring information. This reduces troubleshooting time and provides proactive system maintenance data for improved system optimization.

XPR's cutting-edge power supply features advanced chopper circuitry that instantaneously senses and responds to changes in arc voltage and current settings. This sophisticated Arc response technology™ delivers important benefits that reduce operating costs and increase productivity.

Arc response technology™

Automatic torch protection

The chopper module senses the onset of catastrophic electrode blowout failure and shuts down the system, protecting the torch from potential damage and enabling improved consumable utilization.

- Prevents torch failure
- Reduces operating cost

Automatic torch protection

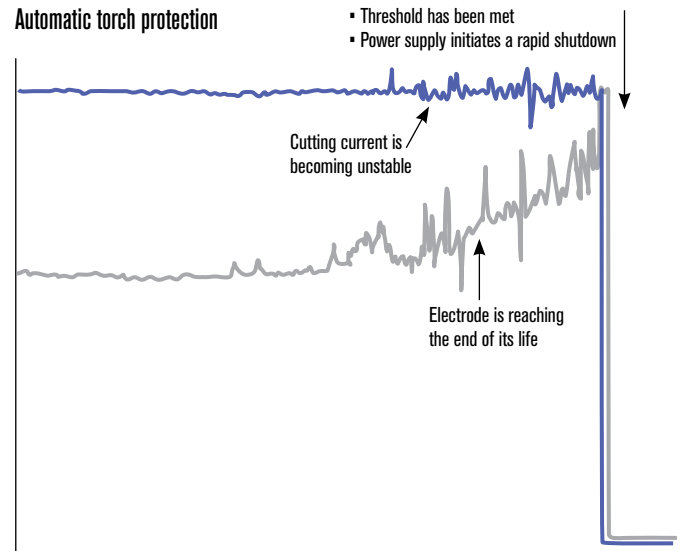

— Cutting current
— Arc voltage
— Plasma pressure

Automatic ramp-down error protection

The chopper module senses when a cut is about to end in an uncontrolled manner – without proper ramp down of current and gas flow. It automatically initiates a rapid ramp-down sequence protecting the electrode, dramatically extending consumable life – over 3 times that of systems that don't have this feature.

- Protects electrode
- Improves realized consumable life
- Reduces operating cost

Ramp-down error protection

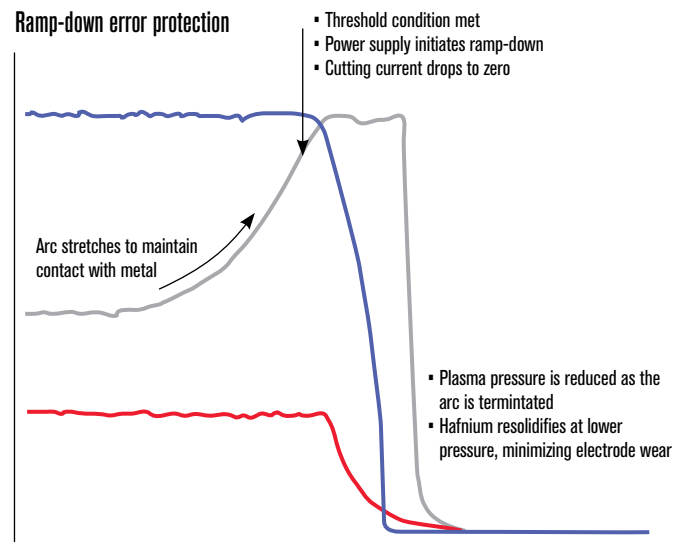

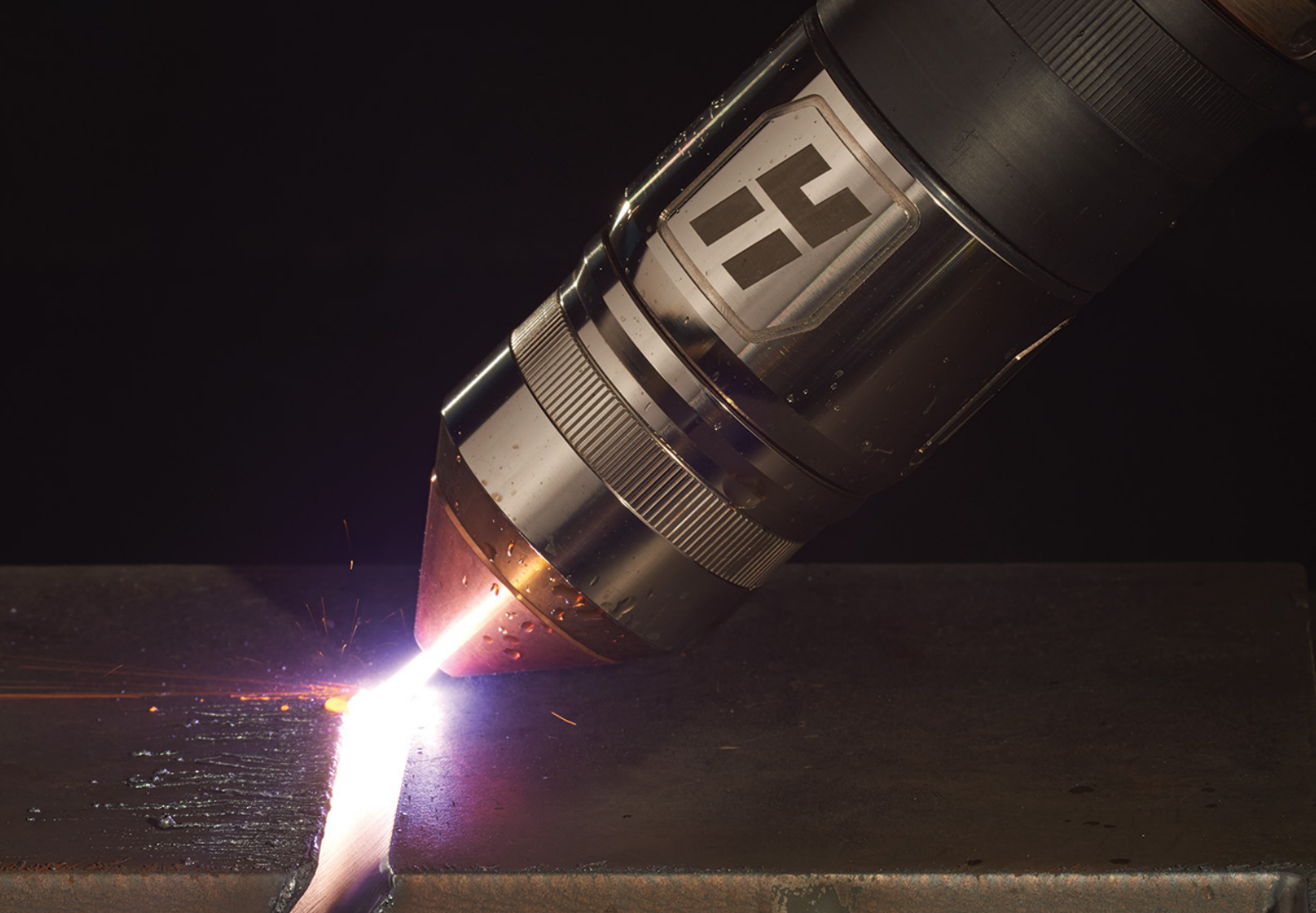

Ease of use

XPR™ sets the new standard for achieving advanced system performance easily. From system set up and installation to connectivity and process optimization, XPR's intuitive operation and automatic system monitoring redefine easy plasma cutting.

- Fewer consoles and connections reduce components and complexity.
- Torch lead includes the EasyConnect™ tool-less connection to the TorchConnect™ console, reducing set up time and simplifying replacement.

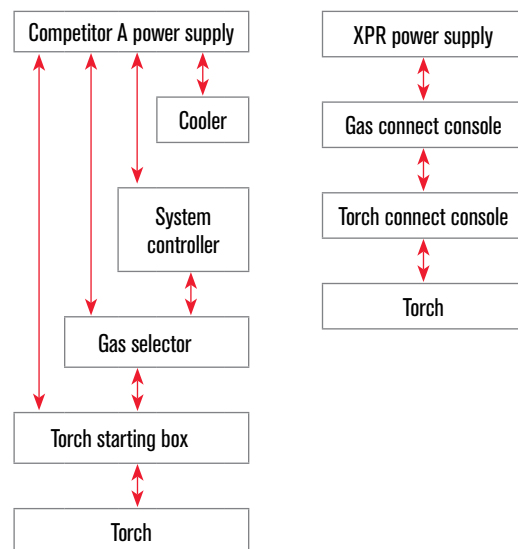

- All consoles feature advanced autogas capability enabling all cutting processes to be selected and driven directly from the CNC.
- Patent pending QuickLock™ electrode delivers easy ¼ turn tightening, reducing job setup time.
- Hypertherm's easiest and fastest torch disconnect design enables a rapid, one handed torch change.

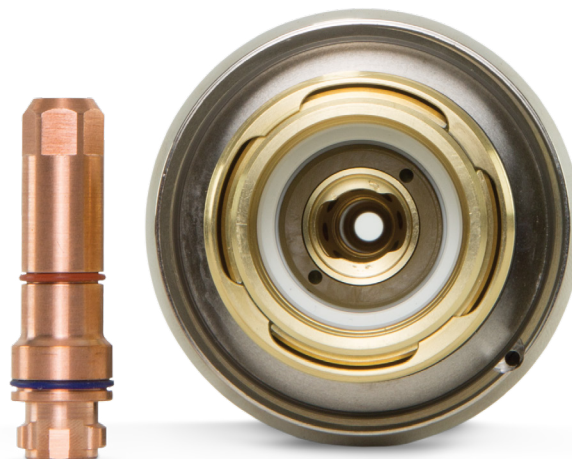

- Built in WiFi connects operating and monitoring abilities to the mobile device dashboard.
- Easy to navigate and read.
- Allows the selection of cutting processes and the monitoring of multiple systems from most mobile devices and laptops.

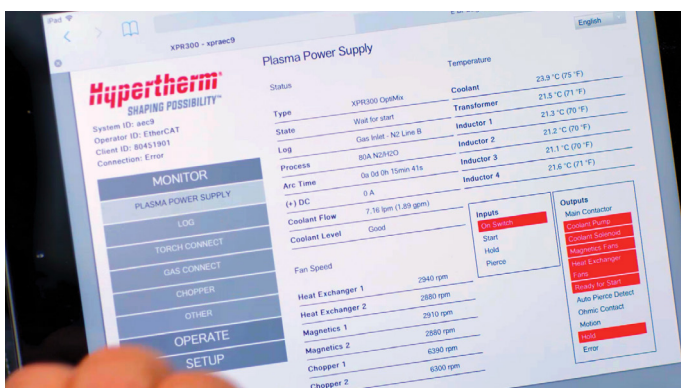

Environmental benefits

The engineering mission at Hypertherm is to develop innovative technologies, products, and solutions that provide superior value to our customers, our owners, and our planet. We consider it critical to our success to reduce the environmental impact of everything we do. The XPR systems have been designed to be more efficient and less wasteful by reducing consumable use, energy and the carbon footprint.

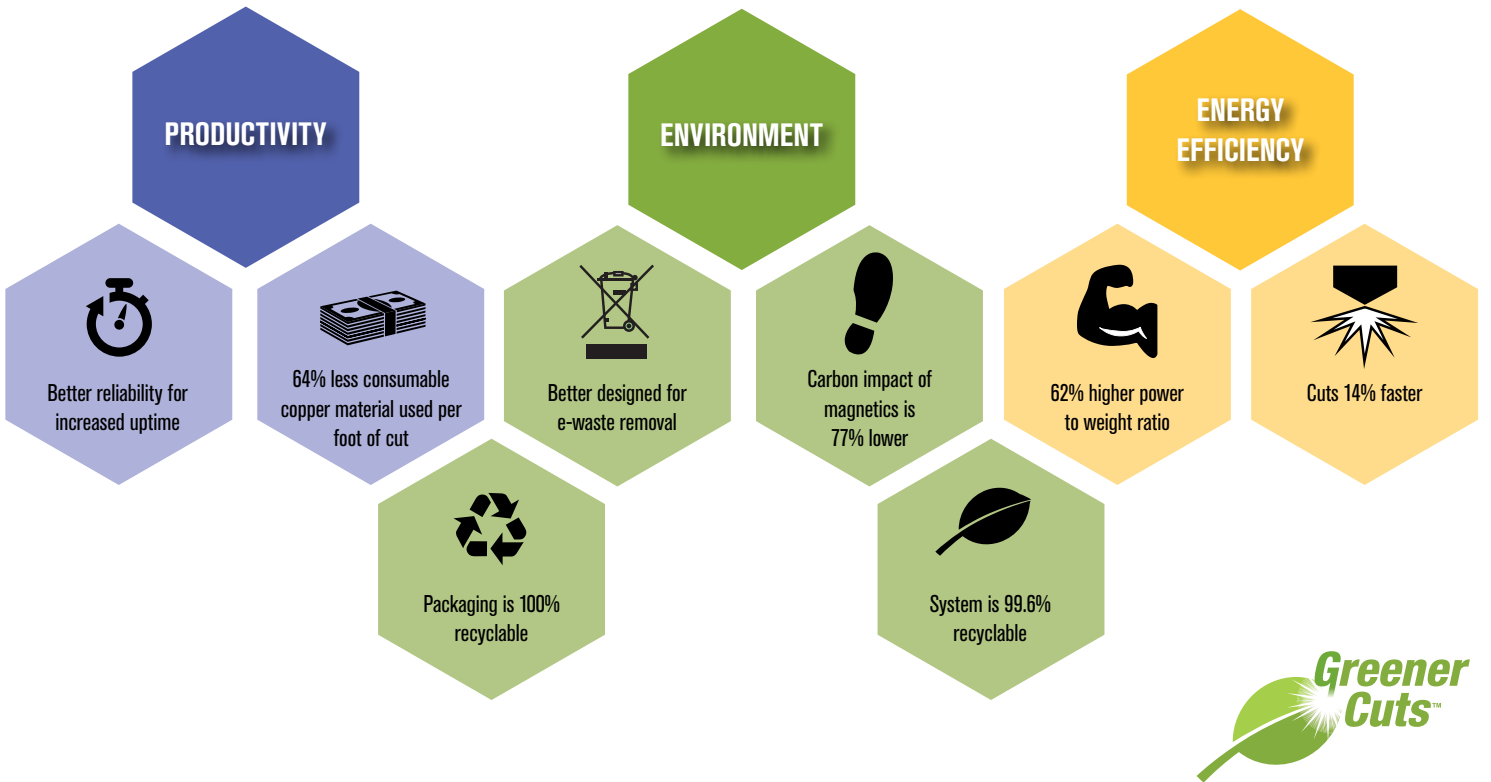

Reliability

XPR's engineering development is the culmination of tens of thousands of hours in testing, data analysis, and system tuning. Our development optimizes your uptime ensuring reliable machine performance even under highly stressful field conditions. The XPR™ is Hypertherm's smartest mechanized plasma system to date. On-board sensors continually monitor current, pressure, temperature, flow and compare to specifications during your operation to ensure optimum performance.

Specifications

General	XPR170	XPR300
Maximum open-circuit voltage	360 VDC	360 VDC
Maximum output current	170 A	300 A
Maximum output power	35,7 kW	66,5 kW
Output voltage	50-210 VDC	50-222 VDC
100% duty arc voltage	210 V	222 V
Duty cycle rating	100% at 35,7 kW, 40° C	100% at 66,5 kW, 40° C
Operational ambient temperature range	-10° C-40° C	-10° C-40° C
Power factor	0,98 @ 35,7 kW	0,98 @ 66,5 kW
Cooling	Forced air (Class F)	Forced air (Class F)
Insulation	Class H	Class H
EMC emissions classification (CE models only)	Class A	Class A
Lift points	Top lift eye weight rating 454 kg	Top lift eye weight rating 680 kg
	Bottom lift truck slots	Bottom lift truck slots

Console	Cutting gases	Current (A)	Thickness (mm)	Approximate cutting speed (mm/min)
Mild steel				
Core, VWI, and OptiMix	O ₂ plasma O ₂ shield	30	0,5	5348
			3	1153
			5	726
	O ₂ plasma Air shield	50	3	3820
			5	2322
			8	1369
	O ₂ plasma Air shield	80	3	5582
			6	3048
			12	1405
	O ₂ plasma Air shield	130	3	6502
			10	2680
			38	256
O ₂ plasma Air shield	170	6	5080	
		12	3061	
		25	1175	
O ₂ plasma Air shield	300	60	152	
		12	3940	
		25	1950	
N ₂ shield	300	50	560	
		80	165	
		Stainless steel		
Core, VWI, and OptiMix	N ₂ plasma N ₂ shield	40	0,8	6100
			3	2683
			6	918
VWI and OptiMix	F5 plasma N ₂ shield	80	3	4248
			6	1916
			12	864
OptiMix	H ₂ -Ar-N ₂ plasma N ₂ shield	170	10	1975
			12	1735
			38	256
	H ₂ -Ar-N ₂ plasma N ₂ shield	300	12	2038
			25	1040
			50	387
VWI and OptiMix	N ₂ plasma H ₂ O shield	300	75	162
			12	2159
			25	1302
Aluminum	Air plasma Air shield	40	1,5	4799
			3	2596
			6	911
VWI and OptiMix	N ₂ plasma H ₂ O shield	80	3	3820
			6	2203
			10	956
	N ₂ plasma H ₂ O shield	130	6	2413
			10	1702
			20	870
N ₂ plasma H ₂ O shield	300	12	2286	
		25	1302	
		50	524	
OptiMix	H ₂ -Ar-N ₂ plasma N ₂ shield	300	12	3810
			25	2056
			50	391

This does not represent a complete list of processes or thicknesses that are available

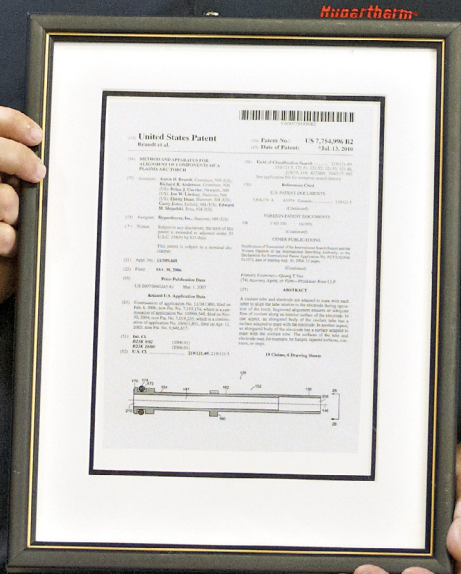

United States Patent

Michael J. Kugaerthelm

Patent No. US 7,382,996 B2

Date of Patent: Feb. 13, 2006

Method of Application of a Sealant

Abstract

Claims

References

Technical Drawing

FIG. 1

FIG. 2

FIG. 3

FIG. 4

50 years of Shaping Possibility

With the right tools and a relentless focus on innovation, partnership, and community, we believe anything is possible.

Fifty years ago, in a small two car garage, Hypertherm® began our journey with simple, powerful ideas about business and an invention that shaped the future of industrial cutting. The same ideals that fueled our inception all those years ago are still what drive us today: A passion for challenging what is achievable with the products we create, the culture we foster, and the experience we deliver to our customers. As we look to the horizon and the next 50 years, we are proud that our people, partners, and innovations will shape the future with solutions that make anything possible for industries around the world.

At Hypertherm, we give shape to our customers' vision with the world's leading industrial cutting solutions. Every day we help individuals and companies around the world envision better, smarter and more efficient ways to produce the products that shape our world. So whether you're cutting precision parts in North America, constructing a pipeline in Norway, fabricating agricultural machinery in Brazil, cutting stone in Italy, gouging out welds in the mines of South Africa, or building a skyscraper in China, you can count on Hypertherm to help you not just cut parts but achieve your vision.

100% employee ownership matters

At Hypertherm, we are not just employees: we are all owners. Ownership is a powerful motivator that ensures our customers are our top priority. As owners, we make sure every product is built to the highest quality and that our service is second to none. And we build long-term relationships that deliver value for us, our partners and our customers.

Worldwide presence and strength

Hypertherm is a key partner for your fabrication needs and has built a global organization focused on providing high-performance cutting solutions.

Key elements of the Hypertherm formula include:

- Dedicated Associates focused on customer-centered product design and support
- Local sales and service
- Broad application experience and proven results
- Sustainable and ethical business practices benefit our customers and communities

**HELPING YOU
SHAPE THE WORLD.**



PLASMA | LASER | WATERJET | AUTOMATION | SOFTWARE | CONSUMABLES

For location nearest you, visit:
www.hypertherm.com

HyPerformance, X-Definition, HyDefinition, XPR, HPR, Core, Vented Water Injection, PowerPierce, True Hole, OptiMix, HDi, Cool nozzle, Arc response technology, EasyConnect, and QuickLock are trademarks of Hypertherm, Inc. and may be registered in the United States and/or other countries

Environmental stewardship is one of Hypertherm's core values, and it is critical to our success and our customers' success. We are striving to reduce the environmental impact of everything we do. For more information: www.hypertherm.com/environment.

100% employee owned

© 6/2019 Hypertherm, Inc. Revision 3

89706D



Hypertherm[®]
SHAPING POSSIBILITY[®]

